

Product:

WALL COUNTER, ELEMENTS AND COMPOSITIONS

BUFFET includes a variety of high tables, hanging modules, shelves, columns and useful storage units that can be combined, creating different compositions for coffee-break, self-service and restaurant areas. The high table can be equipped with drawer cabinets, drawers and appliances for housing, with retractable multi-socket and top access.

It has also dedicated compartments for sinks, mixers and induction hobs. The available appliances are fridge (to be installed under a top or a column), combi oven, dishwasher, water dispenser and coffee machine.

Hanging modules and open shelves allow to create a variety of configurations for bar, cafeteria, self service areas and restaurant.



TECHNICAL FEATURES

Two wall counter options are available:

1. Wall counters only with shelves or shelves and carter;
2. Wall counters with base storage units.

The wall compositions are completed with the addition of columns, wall shelves and hanging modules.

A set of additional terminal panels (in melamine, lacquered finish or veneer) must be added when using one or more base storage units.

A set of additional terminal panels is not needed to the compositions when using one or more columns, but terminal panels can be in lacquered finish or veneer.

Metal components are in the same finish as the MORE structure, available both in powder coated or Luxury metal (with a surcharge).

If the structure finish is no specified, it is in Titanio finish.

Example 1.

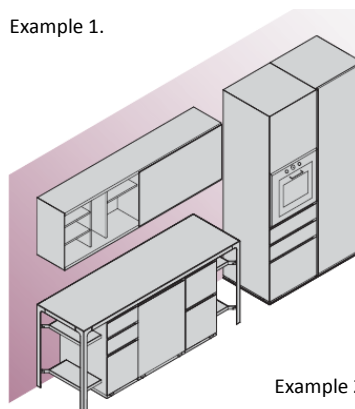

Example 2.

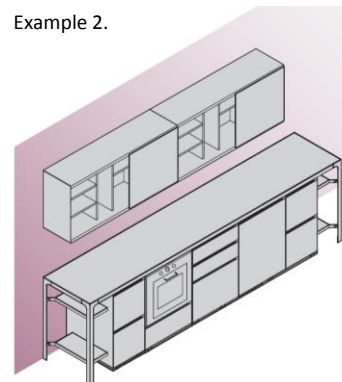

Example 4.

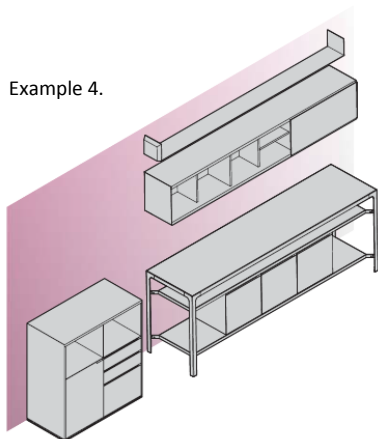

Example 3.

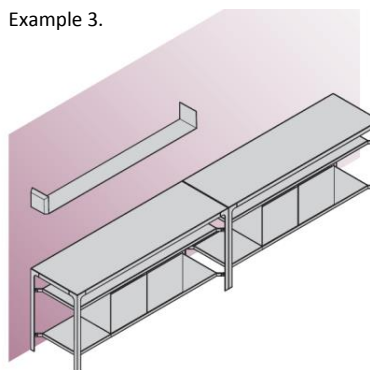

TYPES OF WALL COUNTERS.

D60 (23"5/8) wall counter with shelves.

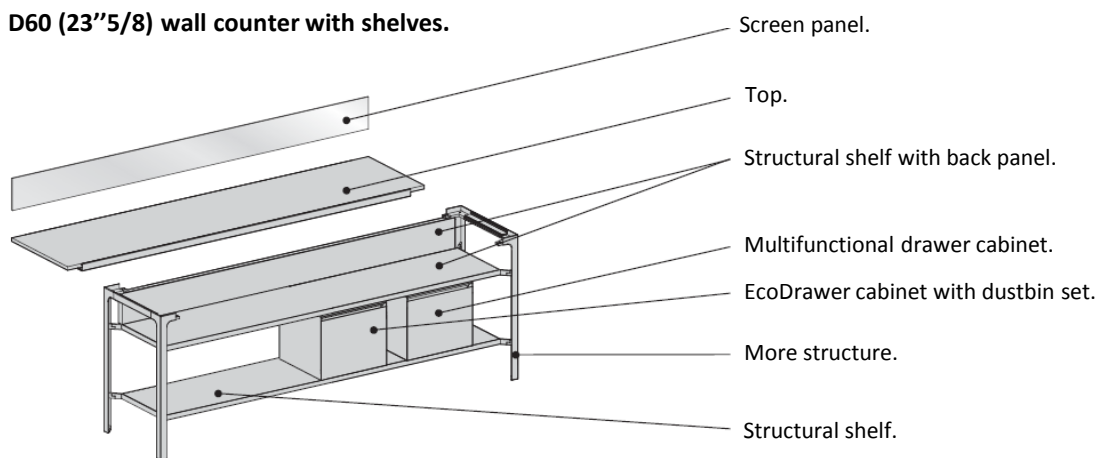

D60 (23"5/8) wall counter with shelves and carter.

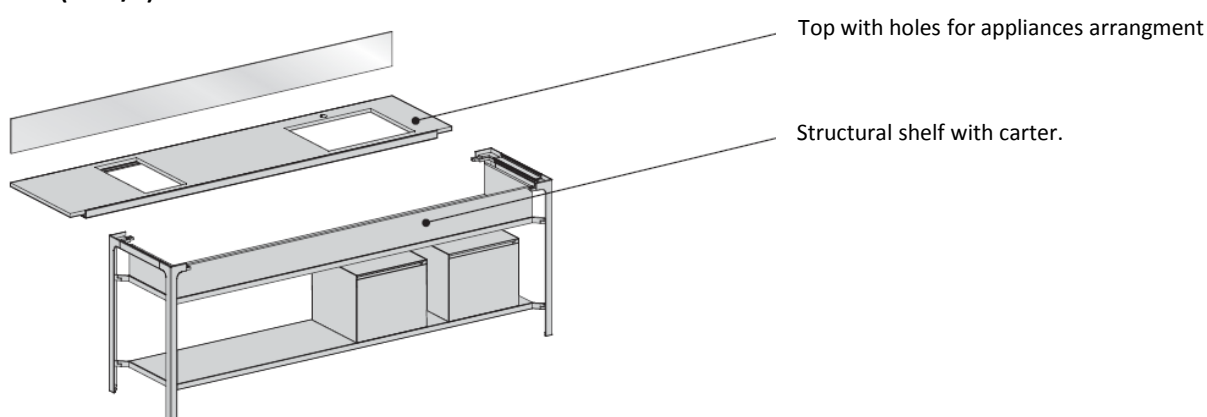

D60 (23"5/8) wall counter with base storage units.

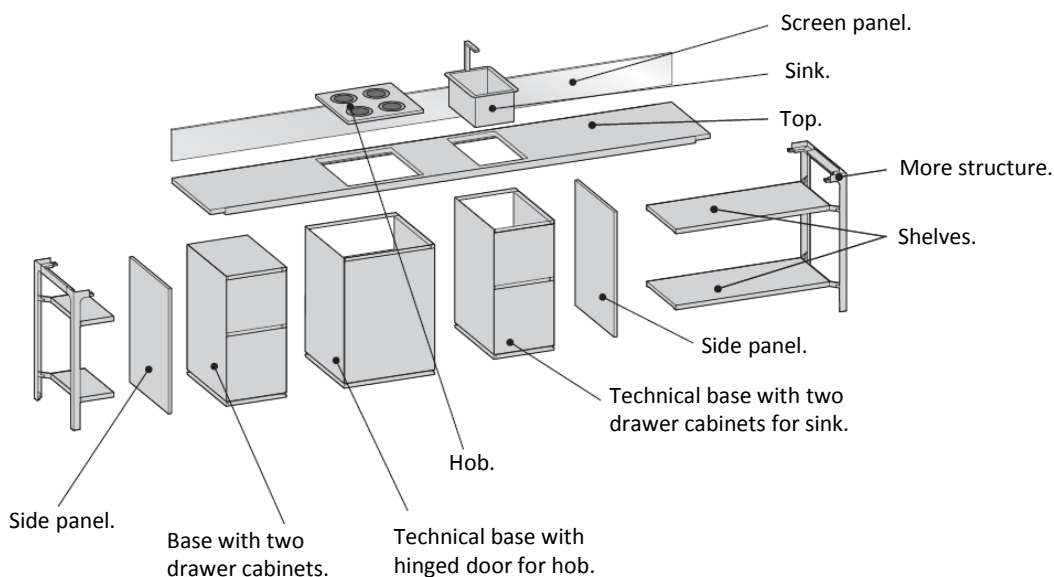

1) WALL COUNTER WITH SHELVES AND CARTER.

DIMENSIONS

W 100 (39"3/8) counter

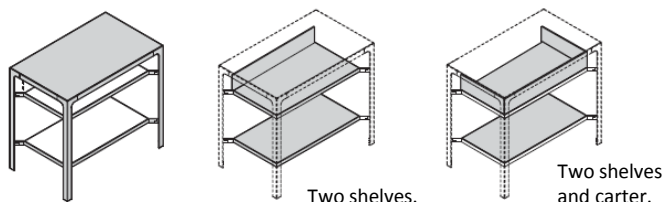

All the wall counters in the pictures:

- are available with two shelves and two shelves and canteen (see W100 counter example);
- are recommended for top with appliances;
- for all wall counters in the pictures, when shelves are in Ceramic the canteen is in Sable Lacquered finish.

W 120 counter (4"1/4)



W 140 counter (55"1/8)

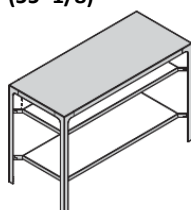

W 160 counter (63")

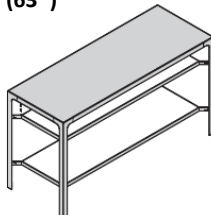

W 180 counter (70"7/8)

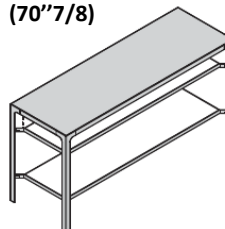

W 200 counter (78"3/4)

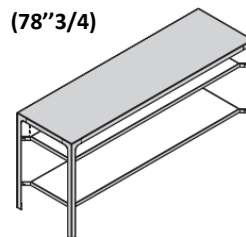

FINISHES

Structure:

Powder coated metal: matt or glossy White Snow, glossy UE White, glossy Silver, matt Titanio, matt Green Black, matt Brown, matt Carbon Glacè, glossy Alfa Red.

Luxury metal: Chromed, glossy Nickel Black, matt Bronze, matt Brass, matt Antique Brass, Pewter Quarz, Brunished Cobalt.

Top:

Laminate: White Snow, Oak, White Fenix.

Stainless Steel.

Ceramics: Calacatta Soft, Calacatta Glossy, Statuario Soft, Statuario Glossy, Walks 1.0 White, Walks 1.0 Gray, Le Roche Ecrù, Ardoise Ecrù, Ardoise Noir, Nero Marquinia, Le Roche Grey, Industrial Ivory, Industrial Plomb.

Back lacquered-etched glass: White, Silver, Titanio, Brown, Alfa Red.

Shelves for top and canteen:

Melamine: UE White, Silver, Titanio, Delavè, Comfort, White Snow, Magnolia, Oak 2017, Eucalyptus, White Colour Fir.

Laminate: see finishes for top.

Sablè lacquered, available in different sample collection colours.

Veneer: Magnolia, White Colour Fir, Nuvola stained Oak, Natural Oak 2016, American Walnut, Eucalyptus, Wengè, Zebrano Brown, Ebano.

Ceramics: see finishes for top.

ACCESSORIES

Storage units.

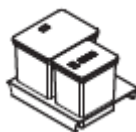

Dustbin set.



W 46 (18"1/8)
D 44,5 (17"1/2)
H 46,5 (18"1/4)

Multifunctional drawer (melamine, lacquered, veneer).

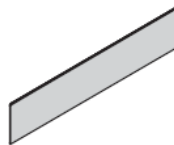

Screen panel (finishes as the top).

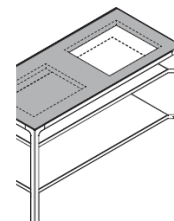

Hole for appliances.

Electrification.



Top access (laminate, lacquered).

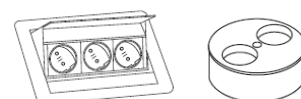

Multiple-socket.



2) WALL COUNTER WITH BASE STORAGE UNITS.

DIMENSIONS

W 160 counter
(63")

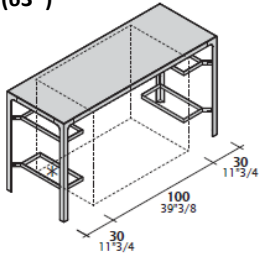

W 180 counter
(70"7/8)

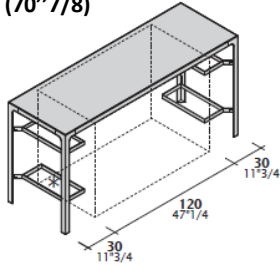

W 200 counter
(78"3/4)

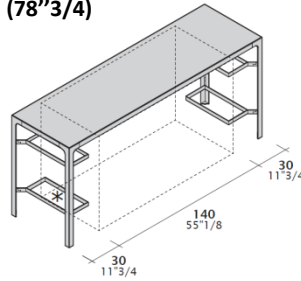

W 220 counter
(86"5/8)

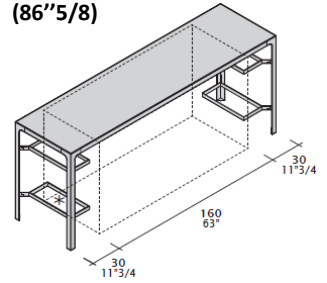

W 240 counter
(94"1/2)

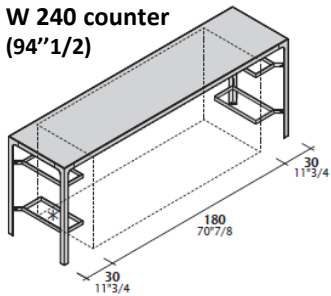

W 260 counter
(102"3/8)

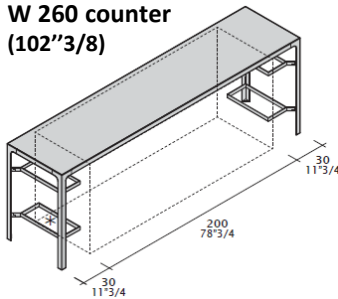

W 280 counter
(110"1/4)

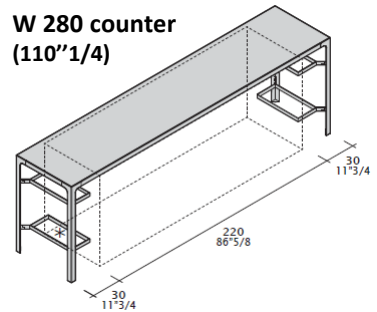

W 300 counter
(118"1/8)

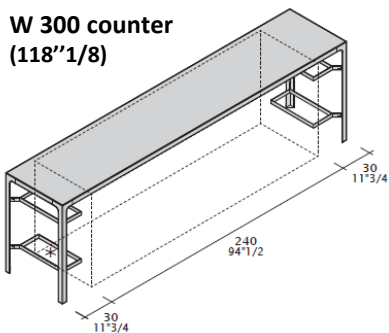

W 320 counter
(126")

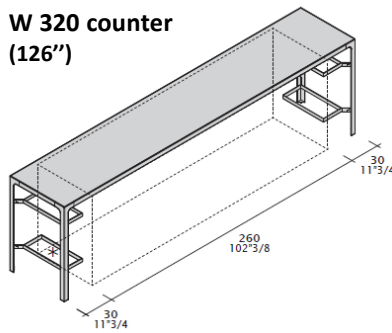

W 340 counter
(133"7/8)

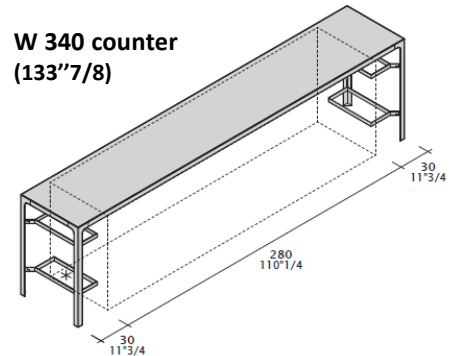

All wall counters in the pictures are combined with four W30 (11"3/4) shelves .

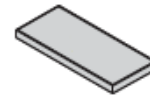

BASE STORAGE UNITS FOR COUNTER - D60 (23"5/8) , H90 (35"5/8)

W40 (15"3/4)

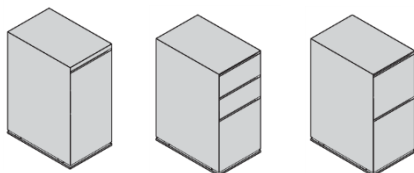

Hinged door.

2 drawers and 1 drawer cabinet.

2 drawer cabinets.

W60 (23"5/8)

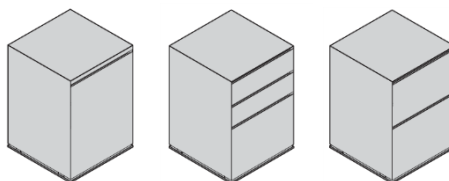

Hinged door.

2 drawers and 1 drawer cabinet.

2 drawer cabinets.

W80 (31"1/2)

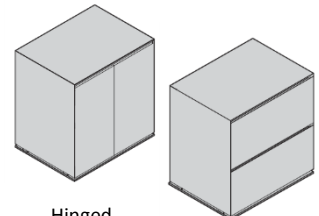

Hinged door.

2 drawer cabinets.

W100 (39''3/8)

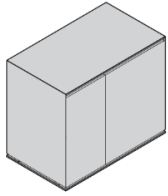

Hinged doors:
W60 (23''5/8)
+ W40 (15''3/4).

ACCESSORIES FOR BASE STORAGE UNITS

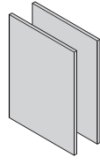

Couple of side panels.

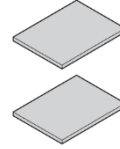

Internal shelves.
W40 (15''3/4)
W60 (23''5/8)
W80 (31''1/2)
W100 (39''3/8)

(frame in powder coated metal).

TECHNICAL BASE STORAGE UNITS FOR COUNTER - D60 (23''5/8) , H90 (35''3/8)

W 40 (15''3/4)

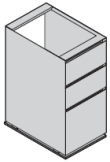

For cooker.

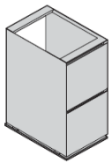

For cooker or sink.

W 80 (31''1/2)

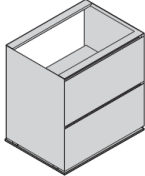

For cooker or sink.

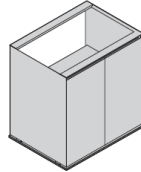

W 100 (39''3/8)

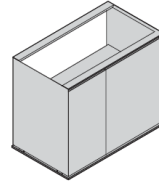

For cooker or sink.

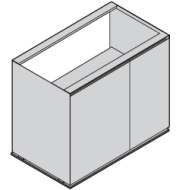

W 60 (23''5/8)

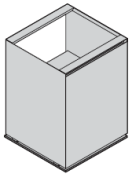

For cooker or sink.

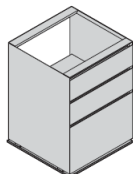
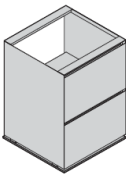

For cooker.

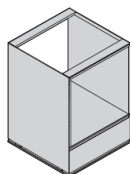

For dishwasher or oven.

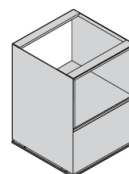

For compact oven or micro fridge drawer.

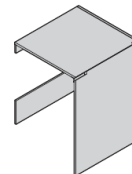

For fridge.

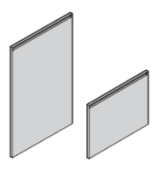

DOOR for fridge, dishwasher or micro fridge drawer.

ACCESSORIES FOR TECHNICAL BASE STORAGE UNITS

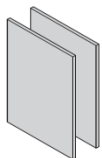

Couple of side panels.

Storage units.

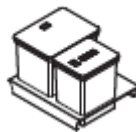

Dustbin set.



Multifunctional drawer (melamine, lacquered, veneer).

L 46 (18''1/8)
P 44,5 (17''1/2)
H 46,5 (18''1/4)

Dustbin set for drawer cabinets.

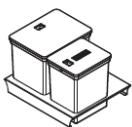

W40 (15''3/4)

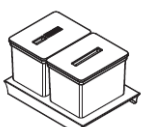

W60 (23''5/8)

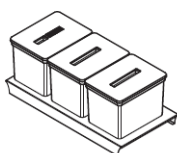

W80 (31''1/2)

Dustbin set for hinged door.

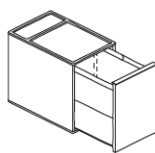

21 LT

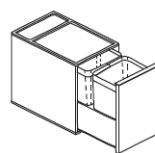

10+10 LT

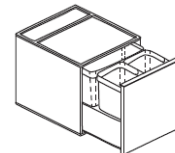

10+10+16 LT

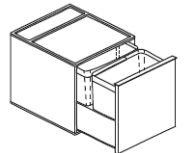

16+21 LT

ACCESSORIES FOR TECHNICAL BASE STORAGE UNITS

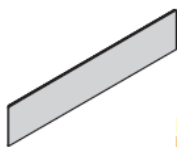

Screen panel
(finishes as the top).

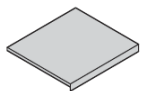

Drawer carter.

Holes for appliances.

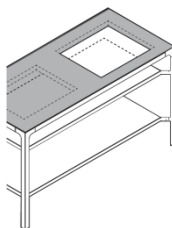

For sink and
cooker.

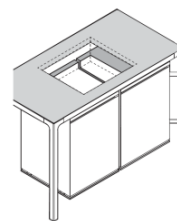

For insertion
between two bases.

Electrification.

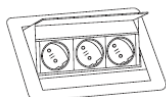

Multiple-socket.

FINISHES

Structure:

Powder coated metal: matt or glossy White Snow, glossy UE White, glossy Silver, matt Titanio, matt Green Black, matt Brown, matt Carbon Glacè, glossy Alfa Red.

Luxury metal: Chromed, glossy Nickel Black, matt Bronze, matt Brass, matt Antique Brass, Pewter Quarz, Brunished Cobalt.

Top:

Laminate: White Snow, Oak, White Fenix.

Stainless steel.

Ceramics: Calacatta Soft, Calacatta Glossy, Statuario Soft, Statuario Glossy, Walks 1.0 White, Walks 1.0 Gray, Le Roche Ecrù, Ardoise Ecrù, Ardoise Noir, Nero Marquinia, Le Roche Grey, Industrial Ivory, Industrial Plomb.

Back-lacquered etched glass: White, Silver, Titanio, Brown, Alfa Red.

W30 shelves for counter/ internal shelves for bases:

Melamine: UE White, Silver, Titanio, Delavè, Comfort, White Snow, Magnolia, Oak 2017, Eucalyptus, White Colour Fir.

Laminate: see finishes for top.

Sablè lacquered, available in different sample colours.

Veneer: Magnolia, White Colour Fir, Nuvola stained Oak, Natural Oak 2016, American Walnut, Eucalyptus, Wengè, Zebrano Brown, Ebano.

Ceramics: see finishes for top.

Normal and technical bases / couple of side panels:

Melamine: see finishes for shelves.

Sablè lacquered, available in different sample colours.

Veneer: see finishes for shelves.



3) COMPOSITION ELEMENTS.

COLUMNS W40 (15"3/4) / W60 (23"5/8)

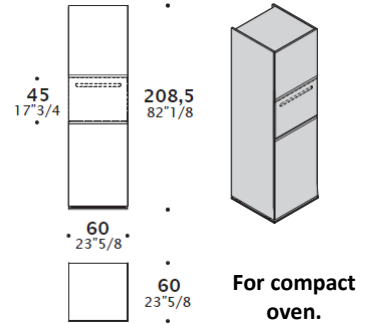
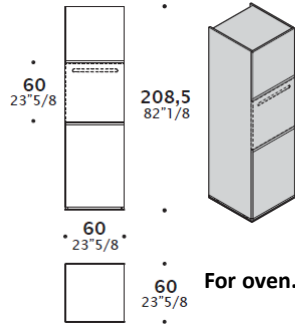
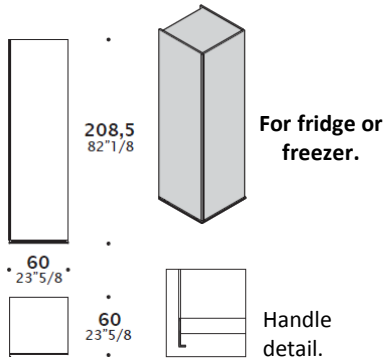

Single column door; also available with two doors.

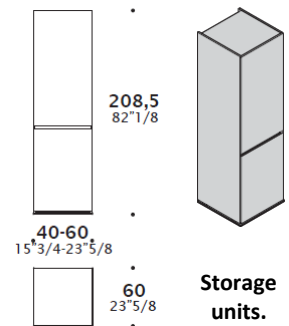
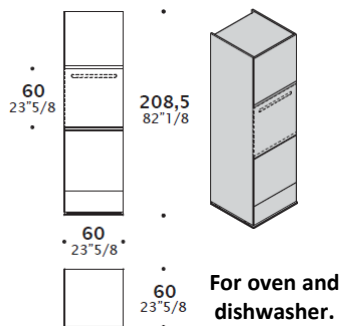
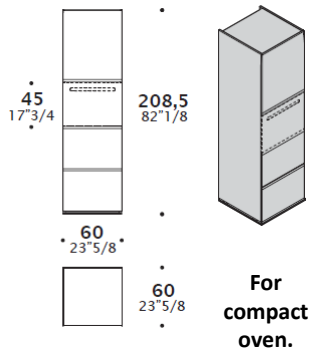
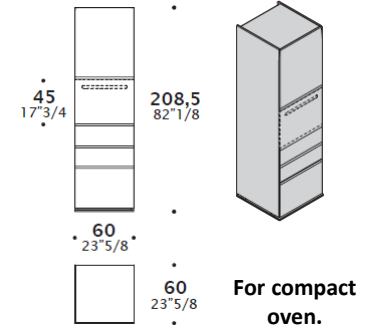
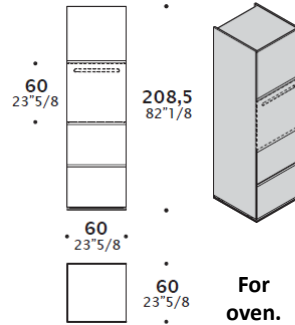
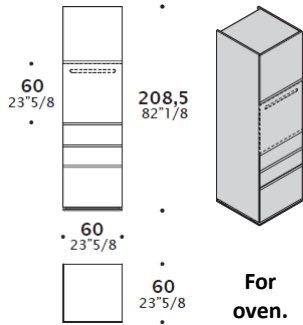

Only for STC75 Smeg dishwasher.

H134 COLUMNS (52"3/4).

The open compartment can be used for compact oven or for coffee machine and water dispenser.

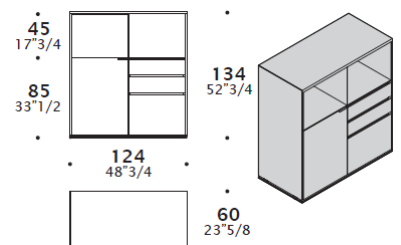
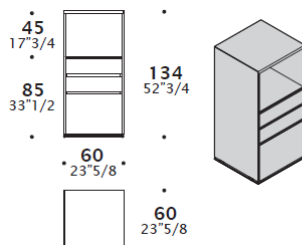
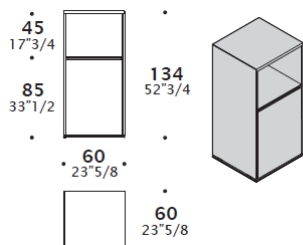

SHELVES

Wall shelves.

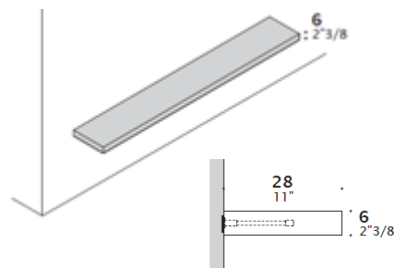
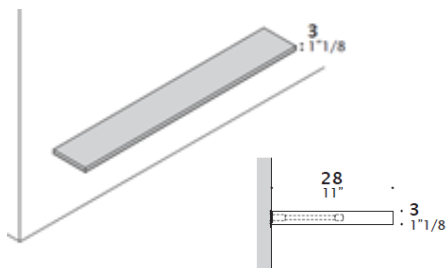

Width:

100 (39"3/8) - 120 (47"1/4) - 140 (55"1/8) - 160 (63") - 180 (70"7/8) - 200 (78"3/4) - 220 (86"5/8) - 240 (94"1/2) - 260 (102"3/8) - 280 (110"1/4) - 300 (118"1/8) - 320 (126")

Shelves.

D 21 (8"1/4)

W 80 (31"1/2) - 120 (47"1/4) - 160 (63") - 200 (78"3/4)

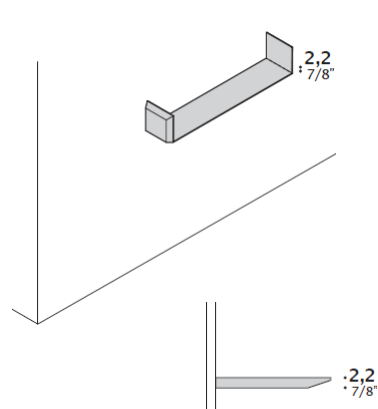
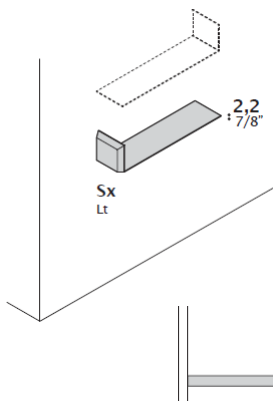
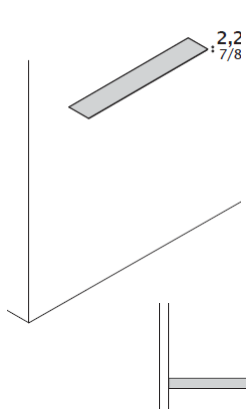

FINISHES

Columns:

Melamine: UE White, Silver, Titanio, Delavè, Comfort, White Snow, Magnolia, Oak 2017, Eucalyptus, White Colour Fir.

Sablè lacquered, available in different sample collection colours.

Veneer: Magnolia, White Colour Fir, Nuvola stained Oak, Natural Oak 2016, American Walnut, Eucalyptus, Wengè, Zebrano Brown, Ebano.

Shelves:

Sablè lacquered, available in different sample collection colours.

Veneer: see finishes for columns.



HANGING MODULES

SLIDING DOORS

Every hanging module can be mounted with several combination of doors following the instructions listed below.

The maximum slide for each door is equal to its width. On side are shown the combinations of modules and sliding doors. Additional side panel can be placed every 20 cm (7"7/8).

FINISHES

Hanging modules structure / optional accessories:

Melamine: UE White, Silver, Titanio, Delavè, Comfort, White Snow, Magnolia, Oak 2017, Eucalyptus, White Colour Fir.

Sablè lacquered, available in different sample colours.

Veneer: Magnolia, White Colour Fir, Nuvola stained Oak, Natural Oak 2016, American Walnut, Eucalyptus, Wengè, Zebrano Brown, Ebano.

Sliding doors:

Sablè lacquered, available in different sample colours.

Veneer: see finishes for hanging modules structure.

Ceramics: Calacatta Soft, Calacatta Glossy, Statuario Soft, Statuario Glossy, Walks 1.0 White, Walks 1.0 Gray, Le Roche Ecrù, Ardoise Ecrù, Ardoise Noir, Nero Marquinia, Le Roche Grey, Industrial Ivory, Industrial Plomb.

Back-lacquered etched glass: White, Silver, Titanio, Brown, Alfa Red.

Luxury metal: Chromed, glossy Nickel Black, matt Bronze, matt Brass, matt Antique Brass, Pewter Quarz, Brunished Cobalt.

OPTIONAL ACCESSORIES - th. 18 mm (3/4)

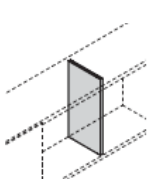

Dividing panel.

H 37 (14"1/2)
H 57 (22"1/2)
D 25 (9"7/8)
D 40 (15"3/4)

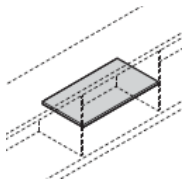

Shelf.

W 40 (15"3/4)
W 60 (23"5/8)
D 25 (9"7/8)
D 40 (15"3/4)

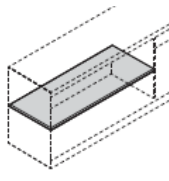

Shelf.

H 37 (14"1/2)
H 57 (22"1/2)
D 25 (9"7/8)
D 40 (15"3/4)

Option:

H 37 + D 25 - 40
H 57 + D 25

Available compositions.

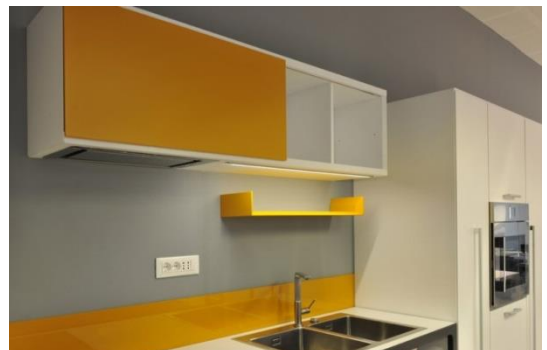
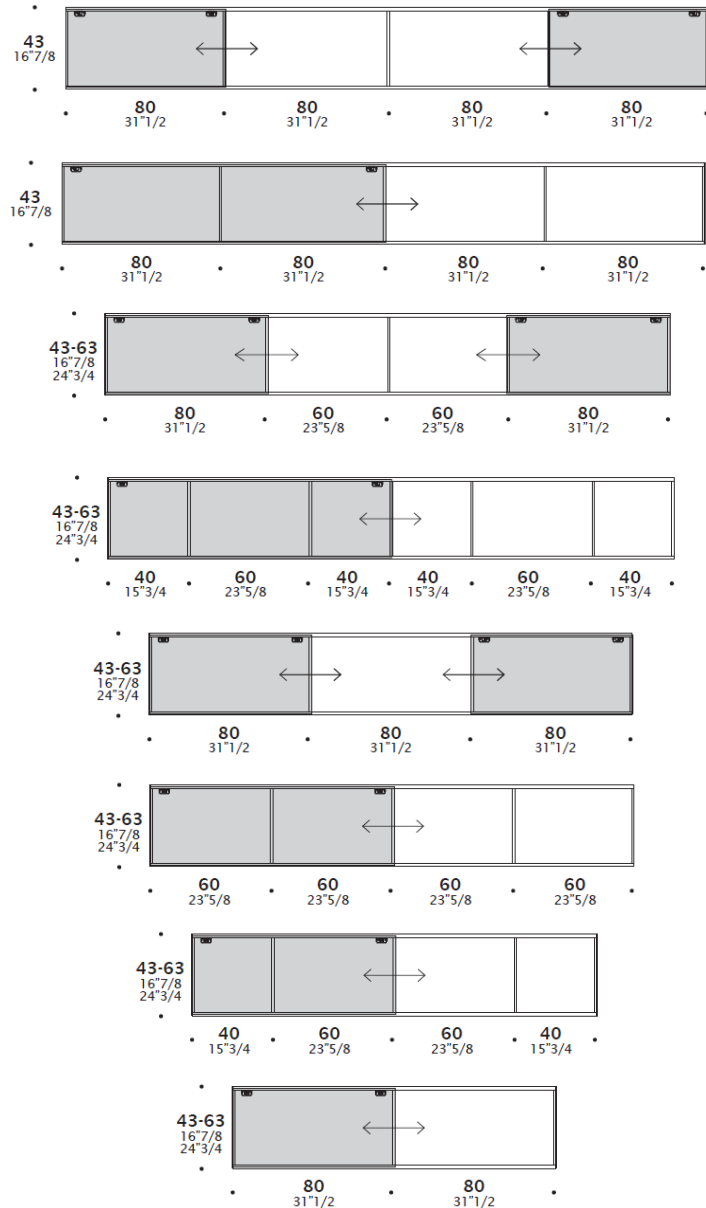

Possibility to have the extractor hood in all sliding door hanging modules (SEE PAGE 11).

DIMENSIONS

The maximum door slide is equal to its width. Also available double below or above height door.

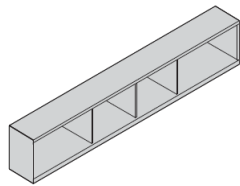

H 43 (16"7/8) - D36 (14"1/8) / 51 (20"1/8)
W 160 (63") - 200 (78"3/4) - 240 (94"1/2) - 280 (110"1/4) - 320 (126")

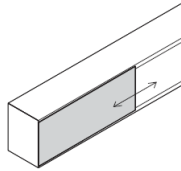

H 40 (15"3/4)
W 80 (31"1/2) - 100 (39"3/8) - 120 (47"1/4) - 140 (55"1/8) - 160 (63")

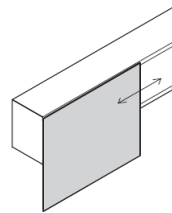

H 80 (31"1/2)
W 80 (31"1/2) - 100 (39"3/8)

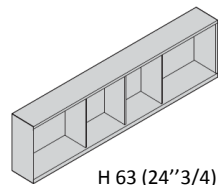

H 63 (24"3/4) - D36 (14"1/8)
W 160 (63") - 200 (78"3/4) - 240 (94"1/2) - 280 (110"1/4)

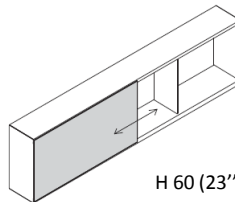

H 60 (23"5/8)
W 80 (31"1/2) - 100 (39"3/8) - 120 (47"1/4) - 140 (55"1/8)

Lighting.

Cables outlet for integrated lighting system must be positioned within the perimeter to the shell itself. The lamps are equipped with power supply. Wires are hidden inside hanging module structure.

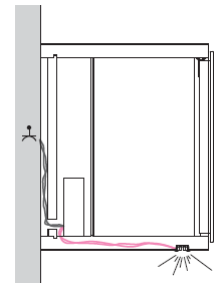
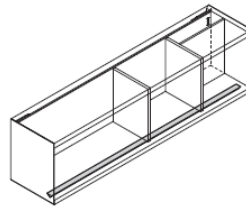

OPEN FRONT HANGING MODULES

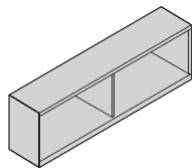

H 43 (16"7/8)
D 35 (13"3/4)
W 80 (31"1/2) - 100 (39"3/8) - 120 (47"1/4) - 140 (55"1/8)

W80, W100, and W120 hanging modules have 1 side panel.
W120 hanging modules have 2 side panels.

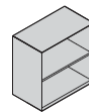

H 63 (24"3/4)

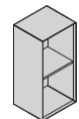

H83 (32"5/8)

D 35 (13"3/4)
W 30 (11"3/4) - 40(15"3/4) - 60 (23"5/8) - 80 (31"1/2)

FNISHES

Hanging modules structure:

Melamine: UE White, Silver, Titanio, Delavè, Comfort, White Snow, Magnolia, Oak 2017, Eucalyptus, White Colour Fir.

Sablè lacquered, available in different sample collection colours.

Veneer: Magnolia, White Colour Fir, Nuvola stained Oak, Natural Oak 2016, American Walnut, Eucalyptus, Wengè, Zebrano Brown, Ebano.



H 123 (48"3/8)
D 35 (13"3/4)
W 30 (11"3/4) - 40(15"3/4)

HINGED DOOR HANGING MODULES

All hanging modules (apart from the last one - H123, D 35, W30-40) can be equipped with extractor hood.

H 63 (24''3/4) - D 35 (13''3/4)

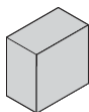

W 30 (11''3/4)
W 40 (15''3/4)
W 60 (23''5/8)

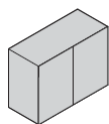

W 80
(31''1/2)

H 83 (32''5/8) - D 35 (13''3/4)

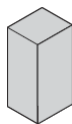

W 30 (11''3/4)
W 40 (15''3/4)
W 60 (23''5/8)

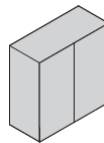

W 80
(31''1/2)



H 123 (48''3/8)
D 35 (13''3/4)
W 30 (11''/4) - 40 (15''3/4)

HINGED DOOR HANGING MODULES

Hinged door in glass with solid wood frame - internal shelves in glass.



H 63 (24''3/4)
D 35 (13''3/4)
W 60 (23''5/8)



H 83 (32''5/8)
D 35 (13''3/4)
W 40 (15''3/4)



H 83 (32''5/8)
D 80 (31''1/2)
W 35 (13''3/4)



H 123 (48''3/8)
D 35 (13''3/4)
W 40 (15''3/4)

FINISHES

Hanging modules structure / hinged doors:

Melamine: UE White, Silver, Titanio, Delavè, Comfort, White Snow, Magnolia, Oak 2017, Eucalyptus, White Colour Fir.

Sablè lacquered, available in different sample collection colours.

Veneer: Magnolia, White Colour Fir, Nuvola stained Oak, Natural Oak 2016, American Walnut, Eucalyptus, Wengè, Zebrano Brown, Ebano.

Door glass / internal shelves: clear glass.

Solid wood frame: Natural Oak, Nuvola stained Oak, American Walnut.

ACCESSORIES

External lighting.

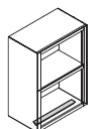

Cable outlet for integrated lighting system must be positioned within the perimeter of the shelf itself. The lamps are equipped with power supply. Wires are hidden inside hanging module structure.

**Extractor hood - for hinged and/or sliding doors .
H 30 (11''3/4) - W60 (23''5/8) - D36 (14''1/8)**

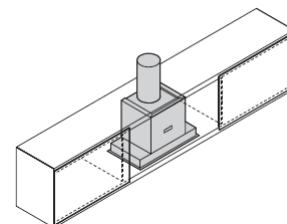
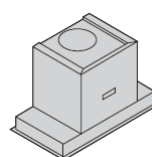

Internal lighting with glass door.

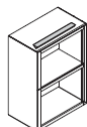

For hanging modules W60 (23''5/8) and W80 (31''1/2).

For all sliding door hanging modules from W160 (63'') to W320 (126'').

COMPOSITION EXAMPLES

W200 (78"3/4)

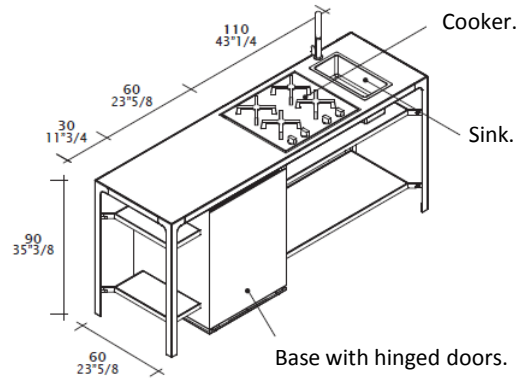
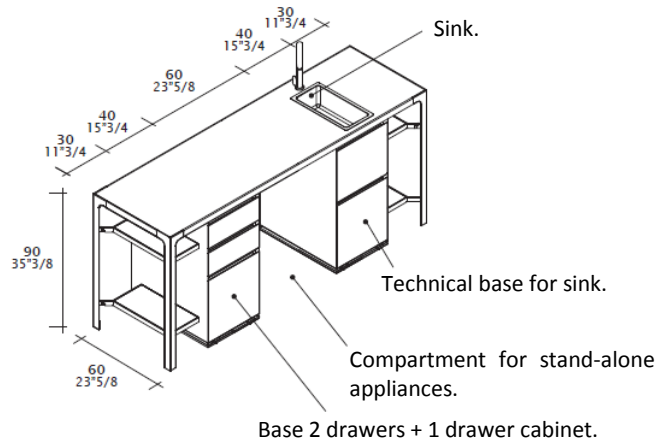
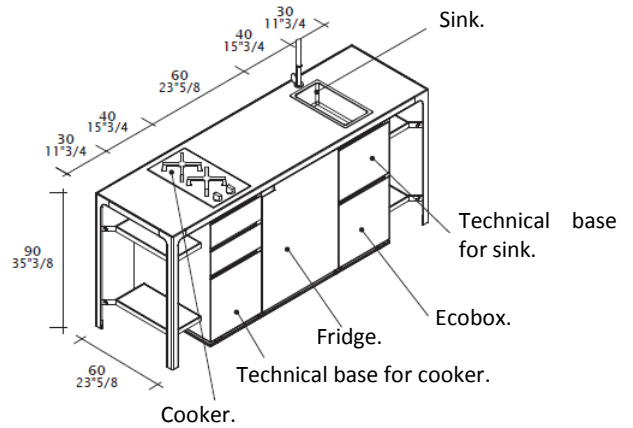
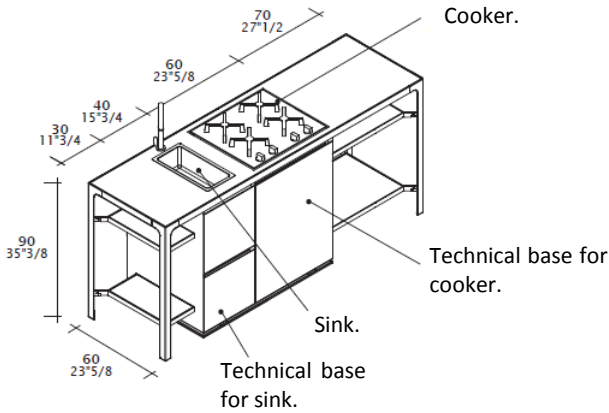

W240 (94"1/2)

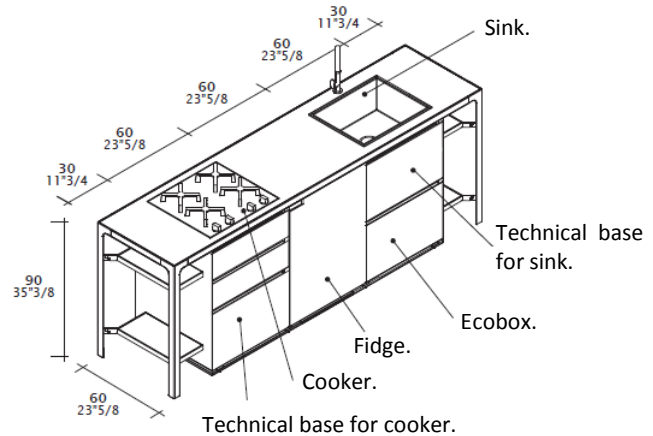
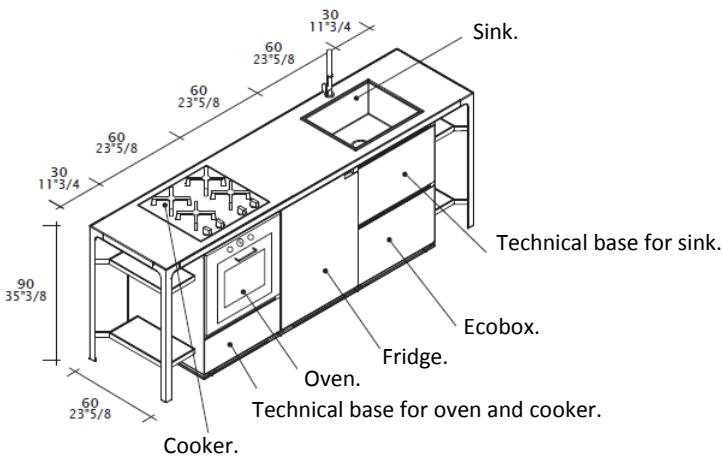

COMPOSITION EXAMPLES

W280 (110"1/4)

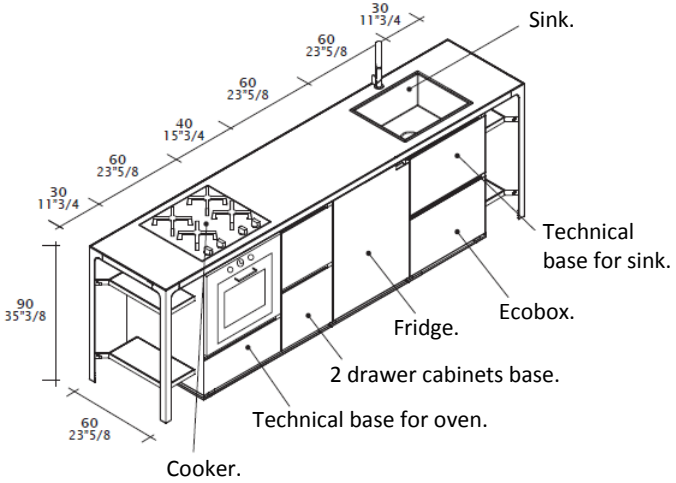
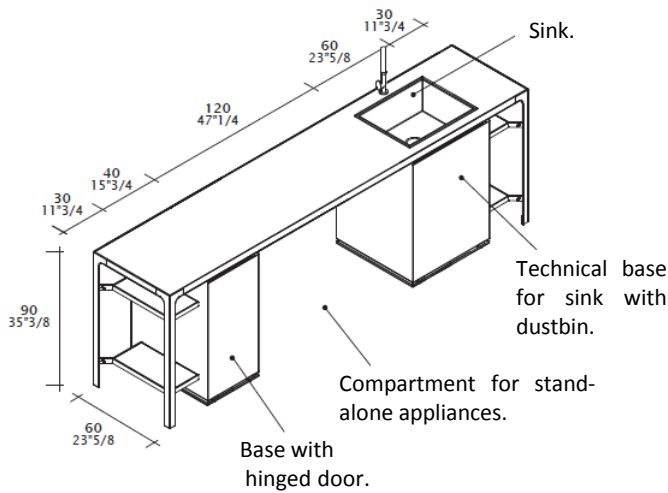
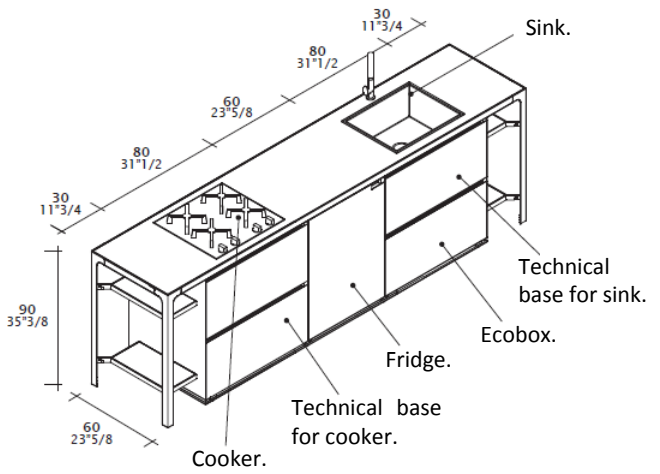
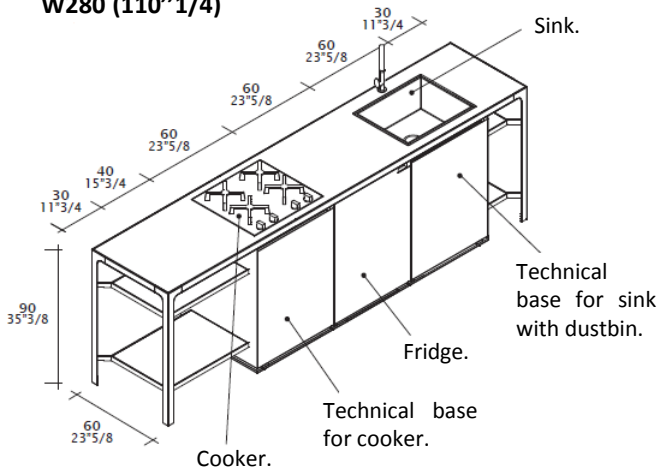

W320 (126")

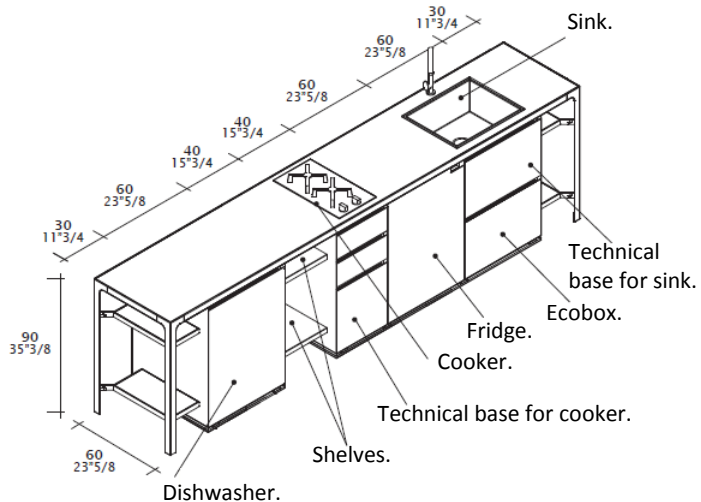
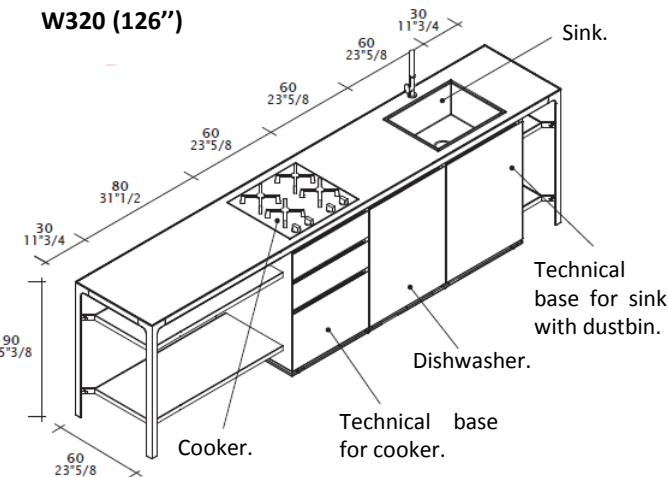

COMPOSITION EXAMPLES

W320 (126")

